



規格承認書

(SPECIFICATION FOR APPROVAL)

File No.: Q/BH .TS16949.13TECH1303

Product Name: DC Filter Capacitor

Product Type: ER10-400(高压直流滤波电容器 定制产品)

Product Code: ER10-400

Customer:

Customer Code:

Issue Date: (V3.0)

DC Filter Capacitors

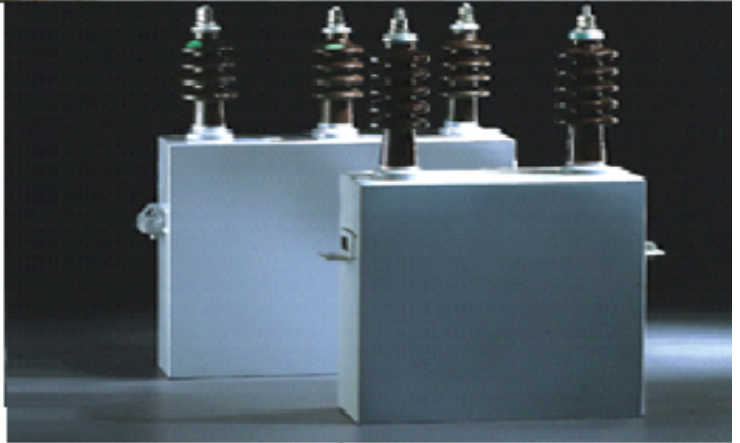

DC Filter Capacitors

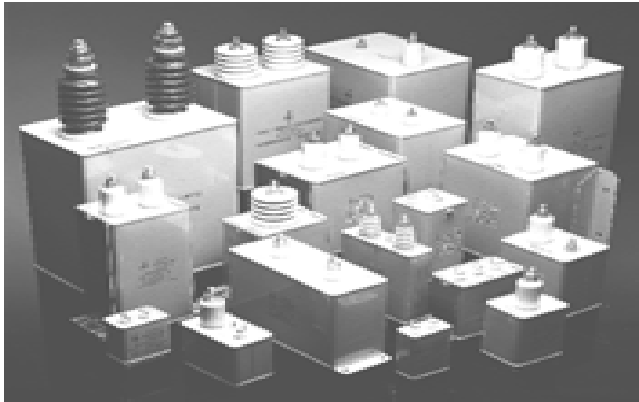

TYPE ER

Capacitors offer unusually good electrical characteristics, coupled with very small size. The ER range of capacitors are manufactured using a mixed dielectric material that consists of polyester/polypropylene. The container is a rolled seamed tinplate case that is hermetically sealed. The construction is designed to prevent internal movement when subjected to shock and vibration.

Note

- The impregnant used is a non toxic highly refined, purified and inhibited mineral oil.

APPLICATIONS

The ER range of capacitors are specifically designed for DC applications.

- Audio coupling
- Pulse forming networks
- Oscillator circuits
- Arc and spark suppression
- RF by-pass
- Tuned filters
- Energy storage
- Integrating circuits
- Low and high pass filters
- High voltage smoothing

Capacitors required for AC applications and high discharge rates can also be designed from the ER range.

Consult Vishay Electronic GmbH, Division Roederstein ESTA and Hybrids for your specific requirements.

TEMPERATURE RANGE

Temperature range is - 55 °C to + 85 °C. The nominal voltage rating is applicable from - 55 °C to + 85 °C.

Derating is required for higher operating temperatures.

TEMPERATURE COEFFICIENT

Capacitance will increase by 2 % per 100 °C temperature change.

RIPPLE

The sum of the peak ripple voltage and the DC voltage should not exceed the rated voltage. Refer to graph fig. 1 for permissible peak-to-peak ripple voltage as a percentage of rated voltage for various frequencies.

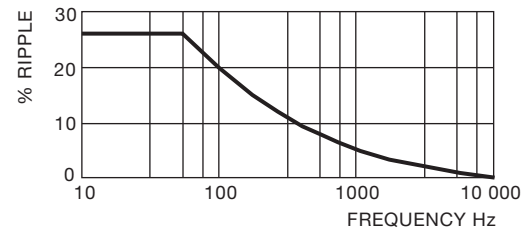

Fig. 1

POWER FACTOR

The power factor is variable, and a function of temperature and frequency. See fig 2. Nominal value < 0.5 % at 20 °C.

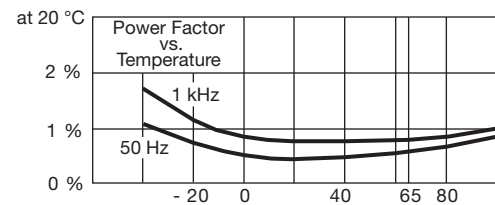

Fig. 2

DIELECTRIC RESISTANCE

(Parallel resistance) is indicated by the graph of insulation ($M\Omega \times \mu F$) vs temperature fig 3. The insulation ($M\Omega \times \mu F$) is nominally 10 000 s at + 20 °C. (Measurements taken after 1 minute with an applied voltage of 500 V).

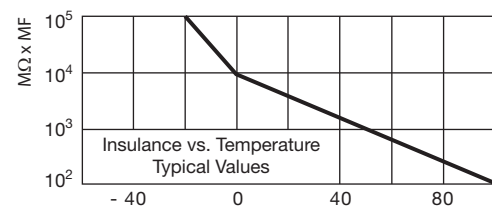

Fig. 3

LIFE EXPECTANCY

ER type capacitors are designed for a life expectancy of 50 000 h at 65 °C. To achieve the same life expectancy at 85 °C derate to 60 % of rated voltage fig 4.

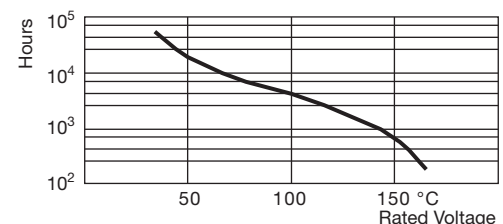

Fig. 4

DC Filter Capacitors

CAPACITANCE RANGE

0.01 μF to 100 μF . The tolerance is $\pm 10\%$. Other tolerances are available on request. Nominal values measured at 1 kHz.

VOLTAGE RANGE

1000 V_{DC} to 40 000 V_{DC} other values on request.

TEST VOLTAGE

Terminal/terminal (Vt/t)

For DC rating < 20 kV

$V_t/t = 2.0 \times \text{rated voltage } 60 \text{ s}$

For DC rating > 20 kV

$V_t/t = 1.5 \times \text{rated voltage } 60 \text{ s}$

WEIGHT

The approximate weight in kg of capacitors in the ER range can be estimated by multiplying the volume of the capacitor container by $1.45^{(1)} \times 10^{-6}$.

TERMINATIONS

Add suffix W to part No. To indicate wire terminations.

CAPACITANCE

Capacitance tolerance of 20 % is standard with those marked ⁽¹⁾.

FLASHOVER

Up to 5000 V rating, the capacitor terminals will withstand 125 % of the rated voltage without flashover at a pressure of 85 mm Hg., equivalent to 50 000 feet altitude. Above 5000 V rating, the capacitor terminals will withstand 125 % of the rated voltage at a pressure of 500 mg Hg, equivalent to 10 000 feet altitude.

LIFE TESTS

Conducted at 85 °C for 500 h. The voltage applied will be 140 % of the rated voltage.

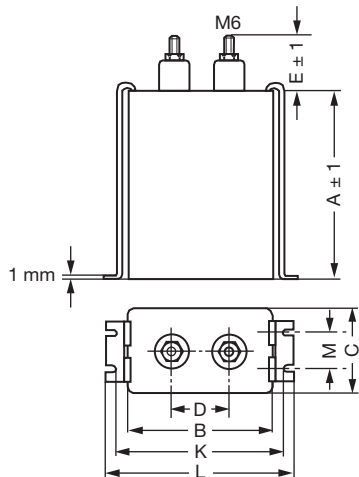

Fig. 5

TYPE DESCRIPTION

PART NUMBER	CAP. μF	A	B	C	D	E
1000 V_{DC} WKG						
ER10-104	0.1	50	48	28	20	20
ER10-504	0.5	50	48	28	20	20
ER10-105	1.0	75	48	28	20	20
ER10-405	4.0	75	60	54	25	35
ER10-605	6.0	95	60	54	25	35
ER10-106	10.0	115	80	48	40	35
ER10-256	25.0	155	85	67	40	35
ER10-506	50.0	155	130	100	50	35
1500 V_{DC} WKG						
ER15-104	0.1	60	48	28	20	20
ER15-504	0.5	60	48	28	20	20
ER15-205	2.0	75	54	48	22	35
ER15-405	4.0	115	54	48	22	35
ER15-805	8.0	95	85	67	40	35
ER15-106	10.0	115	85	67	40	35
ER15-126	12.0	135	85	67	40	35
ER15-256	25.0	115	130	100	50	35
ER15-506	50.0	180	130	100	50	35
2000 V_{DC} WKG						
ER20-104	0.1	60	48	28	20	20
ER20-254	0.25	60	48	28	20	20
ER20-504	0.5	60	48	28	20	20
ER20-105	1.0	95	48	28	20	20
ER20-205	2.0	75	54	48	22	35
ER20-405	4.0	115	54	48	22	35
ER20-605	6.0	135	60	54	25	35
ER20-106	10.0	115	85	67	40	35
ER20-126	12.0	135	85	67	40	35
ER20-206	20.0	115	130	100	50	35
3000 V_{DC} WKG						
ER30-104	0.1	60	48	28	20	20
ER30-504	0.5	75	48	28	20	20
ER30-105	1.0	115	48	28	20	20
ER30-105X	1.0	75	54	48	22	35
ER30-205	2.0	115	54	48	22	35
ER30-405	4.0	155	60	54	25	35
ER30-605	6.0	180	80	48	40	35
ER30-805	8.0	155	85	67	40	35
ER30-106	10.0	95	130	100	50	35
ER30-206	20.0	155	130	100	50	35
ER30-256	25.0	180	130	100	50	35
ER30-104	0.1	60	48	28	20	20
4000 V_{DC} WKG						
ER40-104	0.1	60	48	28	20	20
ER40-254	0.25	75	48	28	20	20
ER40-504	0.5	95	48	28	20	20
ER40-105	1.0	95	54	48	22	35
ER40-205	2.0	135	54	48	22	35
ER40-405	4.0	115	85	67	40	35
ER40-805	8.0	115	130	100	50	35
ER40-106	10.0	135	130	100	50	35
ER40-206	20.0	230	130	100	50	35
ER40-306	30.0	320	130	100	50	35

DC Filter Capacitors

TYPE DESCRIPTION						
PART NUMBER	CAP. μ F	A	B	C	D	E
5000 V_{DC} WKG						
ER50-104	0.1	60	48	28	20	20
ER50-254	0.25	75	48	28	20	20
ER50-105	1.0	115	54	48	22	35
ER50-405	4.0	155	85	67	40	35
ER50-805	8.0	135	130	100	50	35
ER50-106	10.0	155	130	100	50	35
ER50-206	20.0	290	130	100	50	35
ER50-506	50.0	295	180	180	75	35
6000 V_{DC} WKG						
ER60-104	0.1	65	54	48	(1)	35
ER60-254	0.25	80	54	48	(1)	35
ER60-504	0.5	100	80	48	40	35
ER60-105	1.0	100	85	67	40	35
ER60-205	2.0	100	130	100	50	35
ER60-405	4.0	135	130	100	50	35
ER60-605	6.0	180	130	100	50	35
ER60-805	8.0	250	130	100	50	35
ER60-106	10.0	290	130	100	50	35
ER60-126	12.0	345	130	100	50	35
ER60-206	20.0	180	220	164	125	60
8000 V_{DC} WKG						
ER80-503	0.05	58	60	54	(1)	60
ER80-104	0.1	65	60	54	(1)	60
ER80-254	0.25	85	60	54	(1)	60
ER80-504	0.5	140	60	54	(1)	60
ER80-105	1.0	120	85	67	40	60
ER80-205	2.0	120	130	100	50	60
ER80-405	4.0	200	130	100	50	60
ER80-605	6.0	270	130	100	50	60
ER80-805	8.0	345	130	100	50	60
ER80-156	15.0	280	180	180	75	60
10 000 V_{DC} WKG						
ER100-503	0.05	58	80	48	40	60
ER100-104	0.1	65	80	48	54	60
ER100-504	0.5	140	80	48	40	60
ER100-105	1.0	160	85	67	40	60
ER100-205	2.0	140	130	100	50	60
ER100-405	4.0	260	130	100	50	60
ER100-605	6.0	350	130	100	50	60
ER100-805	8.0	300	190	120	75	60
ER100-156	15.0	350	180	180	75	60

TYPE DESCRIPTION						
PART NUMBER	CAP. μ F	A	B	C	D	E
12 000 V_{DC} WKG						
ER120-503	0.05	75	85	67	40	60
ER120-104	0.10	100	85	67	40	60
ER120-254	0.25	105	85	67	40	60
ER120-105	1.0	145	130	100	75	60
ER120-205	2.0	240	130	100	75	60
ER120-405	4.0	280	190	120	75	60
15 000 V_{DC} WKG						
ER150-103	0.01	60	60	54	(1)	60
ER150-203	0.02	60	60	54	(1)	60
ER150-503	0.05	85	60	54	(1)	60
ER150-104	0.10	105	80	48	(1)	60
ER150-254	0.25	125	85	67	40	60
ER150-504	0.50	190	85	67	40	60
ER150-504X	0.50	105	130	100	75	60
ER150-105	1.0	160	130	100	75	60
ER150-205	2.0	190	159	120	75	60
20 000 V_{DC} WKG						
ER200-103	0.01	70	80	48	(1)	60
ER200-503X	0.05	85	85	67	40	60
ER200-104	0.1	105	85	67	40	60
ER200-254	0.25	190	85	67	40	60
ER200-504	0.5	160	130	100	75	60
ER200-105	1.0	300	130	100	75	60
ER200-205	2.0	250	180	180	90	100
ER200-405	4.0	305	240	180	100	100
25 000 V_{DC} WKG						
ER250-503	0.05	110	85	67	(1)	70
ER250-104X	0.1	95	130	100	65	70
ER250-254	0.25	130	130	100	65	70
ER250-504	0.5	250	130	100	65	70
30 000 V_{DC} WKG						
ER300-303	0.03	120	85	67	(1)	70
ER300-104	0.1	200	85	67	(1)	70
ER300-104X	0.1	120	130	100	65	70
ER300-504	0.5	315	130	100	65	70
ER300-105	1.0	295	180	180	75	100
40 000 V_{DC} WKG						
ER400-303	0.03	160	85	67	(1)	70
ER400-503	0.05	210	85	67	(1)	70
ER400-503X	0.05	125	130	100	65	70

Note

(1) These capacitors are fitted with one high voltage terminal and case terminal. An additional terminal for connection to case is available as an optional extra. Add suffix M to part number.